

EE 508

Lecture 9

The Approximation Problem

Classical Approximations



Butterworth
Chebyshev
Elliptic
Bessel
Thomson

Review from Last Time

Least Squares Approximations of Transfer Functions

$$C = \sum_{k=1}^N \left(\frac{\sum_{i=0}^m c_i \omega_k^{2i} - \tilde{H}(\omega_k^2) \sum_{i=0}^n d_i \omega_k^{2i}}{\sum_{i=0}^n d_i \omega_k^{2i}} \right)^2$$

$\langle c_k \rangle$
 $\langle d_k \rangle$

Possible uses of these observations (four algorithms)

1. Guess poles and obtain optimal zero locations
2. Start with a “good” $T(s)$ obtained by any means and improve by selecting optimal zeros
3. Guess poles and then update estimates of both poles and zeros, use new estimate of poles and again update both zeros and poles, continue until convergence or stop after fixed number of iterations
4. Guess poles and obtain optimal zeros. Then invert function and cost and obtain optimal zeros (which are actually poles). Then invert again and obtain optimal zeros. Process can be repeated. - Weighting may be necessary to de-emphasize stop-band values when working with the inverse function

Review from Last Time

Least Squares Approximations of Transfer Functions

$$C = \sum_{k=1}^N \left(\frac{\sum_{i=0}^m c_i \omega_k^{2i} - \tilde{H}(\omega_k^2) \sum_{i=0}^n d_i \omega_k^{2i}}{\sum_{i=0}^n d_i \omega_k^{2i}} \right)^2$$

Comments/Observations about LMS approximations

1. As with collocation, there is no guarantee that $T_A(s)$ can be obtained from $H_A(\omega^2)$
2. Closed-form analytical solutions exist for some useful mean square based cost functions
3. Any of the LMS cost functions discussed that have an analytical solution can have the terms weighted by a weight w_i . This weight will not change the functional form of the equations but will affect the fit
4. The best choice of sample frequencies is not obvious (both number and location)
5. The LMS cost function is not a natural indicator of filter performance
6. It is often used because more natural indicators are generally not mathematically tractable
7. The LMS approach may provide a good solution for some classes of applications but does not provide a universal solution

Pade' Approximations

Consider the polynomial

$$T_D(s) = \sum_{i=0}^{\infty} c_i s^i$$

Define the rational fraction $R_{m,n}(s)$ by

$$R_{m,n}(s) = \frac{\sum_{i=0}^m a_i s^i}{1 + \sum_{i=1}^n b_i s^i} = \frac{A(s)}{B(s)}$$

The rational fraction $R_{m,n}(s)$ is said to be a (m,n) th order Pade' approximation of $T_D(s)$ if $T_D(s)B(s)$ agrees with $A(s)$ through the first $m+n+1$ powers of s

Note the Pade' approximation applies to any polynomial with the argument being either real, complex, or even an operator s

Can operate directly on functions in the s -domain

Pade' Approximations

- Useful for order reduction of all-pole or all-zero approximations
- Can map an all-zero approximation to a realizable rational fraction in the s-domain
- Can extend concept to provide order reduction of higher-order rational fraction approximations
- Can always maintain stability or even minimum phase by reflecting any RHP roots back into the LHP
- Pade' approximation is heuristic (no metrics associated with the approach)
- No guarantees about how good the approximations will be

Approximations

- Magnitude Squared Approximating Functions – $H_A(\omega^2)$
 - Inverse Transform - $H_A(\omega^2) \rightarrow T_A(s)$
 - Collocation
 - Least Squares Approximations (Cost Function Minimization)
 - Pade Approximations
 - Other Analytical Optimizations
 - Numerical Optimization
 - Canonical Approximations
 - Butterworth
 - Chebyshev
 - Elliptic
 - Bessel
 - Thomson
- All special cases of analytical approximations

The Approximation Problem

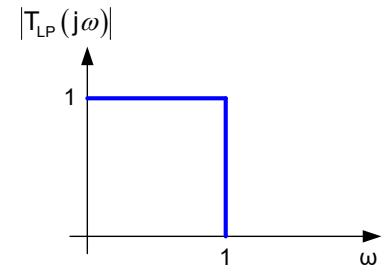

Approach we will follow:

- Magnitude Squared Approximating Functions $H_A(\omega^2)$
- Inverse Transform $H_A(\omega^2) \rightarrow T_A(s)$
- Collocation
- Least Squares (Cost function minimization)
- Pade' Approximations
- Other Analytical Optimization
- Numerical Optimization
-  Canonical Approximations
 - Butterworth (BW)
 - Chebyshev (CC)
 - Elliptic
 - Bessel
 - Thomson

Approximations

- Magnitude Squared Approximating Functions – $H_A(\omega^2)$
- Inverse Transform - $H_A(\omega^2) \rightarrow T_A(s)$
- Collocation
- Least Squares Approximations
- Pade Approximations
- Other Analytical Optimizations
- Numerical Optimization
- Canonical Approximations
 - Butterworth
 - Chebyshev
 - Elliptic
 - Bessel
 - Thomson

On the Theory of Filter Amplifiers.*

By S. Butterworth, M.Sc.

(Admiralty Research Laboratory).

THE orthodox theory of electrical wave filters has been admirably presented by Mr. M. Reed in recent numbers of *E.W. & W.E.* (p. 122, March, 1930 *et seq*), and it is not proposed in the present Paper to add to or to repeat any of that theory. In this work the problem of electrical filtering is attacked from a new angle in which use is made of systems of simple filter units separated by valves so that we combine in one amplifier the property of filtering with that of amplification. The simple units employed can, in the case of low pass filters, be so designed that they take up little more space than the anode resistance employed in the ordinary straight resistance capacity amplifier. The writer

of filter circuit, the first condition is generally approximately fulfilled, but the second condition is usually either not obtained or is approximately arrived at by an empirical adjustment of the resistances of the elements.

The following theory was developed primarily in order to arrive at a logical scheme of design for low pass filters, but it will be shown that it is possible to make use of the theory for band pass, band stop, and high pass filters.

The theory of the general filter-circuit of the Campbell type including resistance is not attempted, but it is shown how to obtain the best results from a two element filter and then how to combine any number of elemen-

Butterworth Approximations

- Analytical formulation:
 - All pole approximation
 - Magnitude response is maximally flat at $\omega=0$
 - Goes to 0 at $\omega=\infty$
 - Assumes value $\sqrt{\frac{1}{1+\varepsilon^2}}$ at $\omega=1$
 - Assumes value of 1 at $\omega=0$
 - Characterized by $\{n,\varepsilon\}$
- Emphasis almost entirely on performance at single frequency

"On the Theory of Filter Amplifiers", Wireless Engineer (also called Experimental Wireless and the Radio Engineer), Vol. 7, 1930, pp. 536-541.

Butterworth Approximations

- Analytical formulation:
 - Magnitude response is maximally flat at $\omega=0$
 - Goes to 0 at $\omega=\infty$
 - Assumes value $\sqrt{\frac{1}{1+\varepsilon^2}}$ at $\omega=1$
 - Assumes value of 1 at $\omega=0$

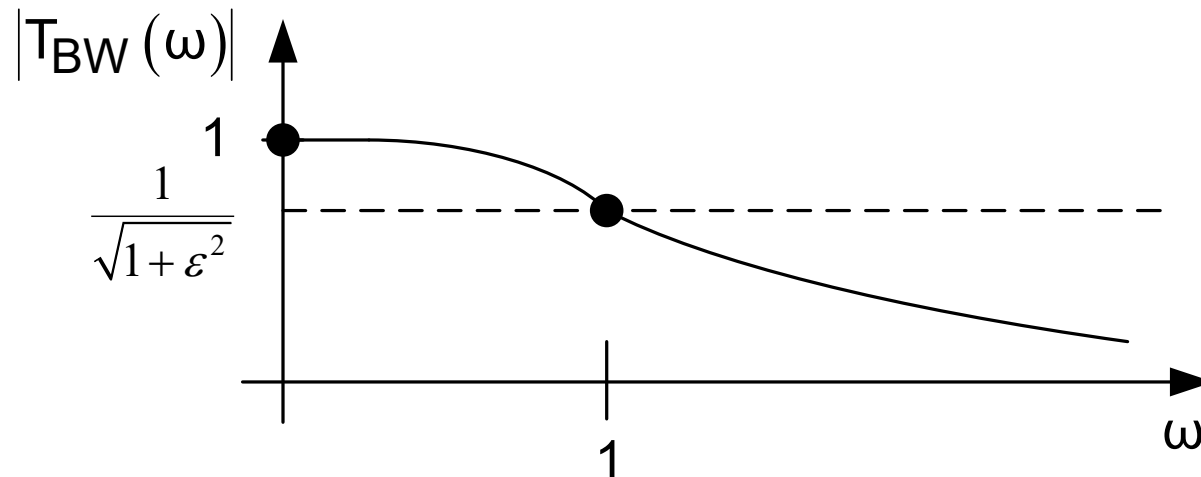

<https://i.stack.imgur.com/KGIHe.jpg>

- *Butterworth Filters*

Stephen Butterworth was a British physicist who invented the Butterworth filter, a class of circuits that are used to filter electrical signals. He worked for several years at the National Physical Laboratory (UK), where he did theoretical and experimental work for the determination of standards of electrical inductance and analyzed the electromagnetic field around submarine cables.



1885-1958

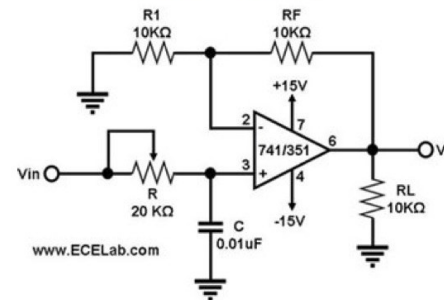



Stephen Butterworth 1885-1958

Stephen Butterworth (1885-1958) was a [British physicist](#) who invented the [Butterworth filter](#)^[1], a class of electrical circuits that are used to [filter](#) electrical signals.

Stephen Butterworth was born on 11 August 1885 in Rochdale, England (a town located about 10 miles north of the city of Manchester). He was the son of Alexander Butterworth, a postman, and Elizabeth (maiden name unknown).^[2] He was the second of four children.^[3] In 1904, he entered the University of Manchester, from which he received, in 1907, both a Bachelor of Science degree in physics (first class) and a teacher's certificate (first class). In 1908 he received a Master of Science degree in physics.^[4] For the next 11 years he was a physics lecturer at the Manchester Municipal College of Technology. He subsequently worked for several years at the National Physical Laboratory, where he did theoretical and experimental work for the determination of standards of electrical inductance. In 1921 he joined the [Admiralty's Research Laboratory](#). Unfortunately, the classified nature of his work prohibited the publication of much of his research there. Nevertheless, it is known that he worked in a wide range of fields; e.g., he determined the electromagnetic field around submarine cables carrying a.c. current,^[5] and he investigated underwater explosions and the stability of torpedos. In 1939, he was a "Principal Scientific Officer" at the Admiralty Research Laboratory in the Admiralty's Scientific Research and Experiment Department.^[6] During World War II, he investigated both [magnetic mines](#) and the [degaussing](#) of ships (as a means of protecting them from magnetic mines).

He was a first-rate applied mathematician. He often solved problems that others had regarded as insoluble. For his successes, he employed judicious approximations, penetrating physical insight, ingenious experiments, and skillful use of models. He was a quiet and unassuming man. Nevertheless, his knowledge and advice were widely sought and readily offered. He was respected by his colleagues and revered by his subordinates.

In 1942 he was awarded the Order of the British Empire.^[7] In 1945 he retired from the Admiralty Research Laboratory. He died on 28 October 1958 at his home in Cowes on the Isle of Wight, England.^[8]^[9]

In *Wireless Engineer* (also called *Experimental Wireless and the Wireless Engineer*), vol. 7, 1930, pp. 536–541 - ["On the Theory of Filter Amplifiers"-S. Butterworth](#)

From: http://en.wikipedia.org/wiki/Butterworth_filter

Butterworth had a reputation for solving "impossible" mathematical problems. At the time [filter design](#) was largely by trial and error because of their mathematical complexity. His paper was far ahead of its time: the filter was not in common use for over 30 years after its publication. Butterworth stated that;

"An ideal electrical filter should not only completely reject the unwanted frequencies but should also have uniform sensitivity for the wanted frequencies."

Butterworth Approximation

$$H(\omega^2) = \frac{a_0}{\omega^{2n} + b_{n-1}\omega^{2n-2} + \dots + b_1\omega^2 + b_0}$$

$$H(1) = \frac{1}{1 + \varepsilon^2}$$

$$H(0) = 1$$

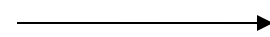

$$a_0 = b_0$$

$$b_0 \neq 0$$

Let $x = \omega^2$

$$H(x) = \frac{a_0}{x^n + b_{n-1}x^{n-1} + \dots + b_1x + b_0}$$

$$\frac{\partial H}{\partial x} = -a_0 \frac{nx^{n-1} + b_{n-1}(n-1)x^{n-2} + \dots + b_1}{(x^n + b_{n-1}x^{n-1} + \dots + b_1x + b_0)^2}$$

$$\left. \frac{\partial H}{\partial x} \right|_{x=0} = -a_0 \frac{nx^{n-1} + b_{n-1}(n-1)x^{n-2} + \dots + b_1}{(x^n + b_{n-1}x^{n-1} + \dots + b_1x + b_0)^2} \Big|_{x=0} = 0$$

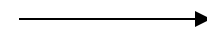

$$b_1 = 0$$

Butterworth Approximation

$$H(x) = \frac{a_0}{x^n + b_{n-1}x^{n-1} + \dots + b_1x + b_0}$$

$$\frac{\partial^2 H}{\partial x^2} = -a_0 \frac{(x^n + b_{n-1}x^{n-1} + \dots + b_1x + b_0)^2 (n(n-1)x^{n-2} + (b_{n-1}(n-1)(n-2)x^{n-2}) + \dots + 6b_3x + 2b_2) - (nx^{n-1} + b_{n-1}(n-1)x^{n-2} + \dots + b_1)^2 2(x^n + b_{n-1}x^{n-1} + \dots + b_1x + b_0)}{(x^n + b_{n-1}x^{n-1} + \dots + b_1x + b_0)^4}$$

$$\left. \frac{\partial^2 H}{\partial x^2} \right|_{x=0} = - \frac{(x^n + b_{n-1}x^{n-1} + \dots + b_1x + b_0)^2 (n(n-1)x^{n-2} + (b_{n-1}(n-1)(n-2)x^{n-2}) + \dots + 6b_3x + 2b_2) - (nx^{n-1} + b_{n-1}(n-1)x^{n-2} + \dots + b_1)^2 2(x^n + b_{n-1}x^{n-1} + \dots + b_1x + b_0)}{(x^n + b_{n-1}x^{n-1} + \dots + b_1x + b_0)^4} \Big|_{x=0} = 0$$

$$\left. \frac{\partial^2 H}{\partial x^2} \right|_{x=0} = 0 \quad \longrightarrow \quad 2b_0^2b_2 - 2b_0b_1^2 = 0$$

$$\longrightarrow \quad b_2 = 0$$

Continuing this process obtain $b_3=0, b_4=0, \dots, b_{n-1}=0$

Butterworth Approximation

$$H(x) = \frac{b_0}{x^n + b_0}$$

$$H(1) = \frac{1}{1 + \varepsilon^2}$$

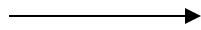

$$b_0 = \frac{1}{\varepsilon^2}$$

$$H(\omega) = \frac{1}{1 + \varepsilon^2 \omega^{2n}}$$

Roots of $H(\omega)$ are poles and are at

$$\omega = \varepsilon^{-1/n} (-1)^{1/(2n)}$$

The $2n$ roots of -1 are uniformly spaced on a circle of radius 1

Butterworth Approximation

$$H(\omega) = \frac{1}{1 + \varepsilon^2 \omega^{2n}}$$

Roots of $H(\omega)$ are poles and are at

$$\omega = \varepsilon^{-1/n} (-1)^{1/(2n)}$$

Poles of $H(\omega)$ are a scaled version of the roots of -1

Roots of -1 are uniformly spaced around a unit circle with symmetry around real and imaginary axis

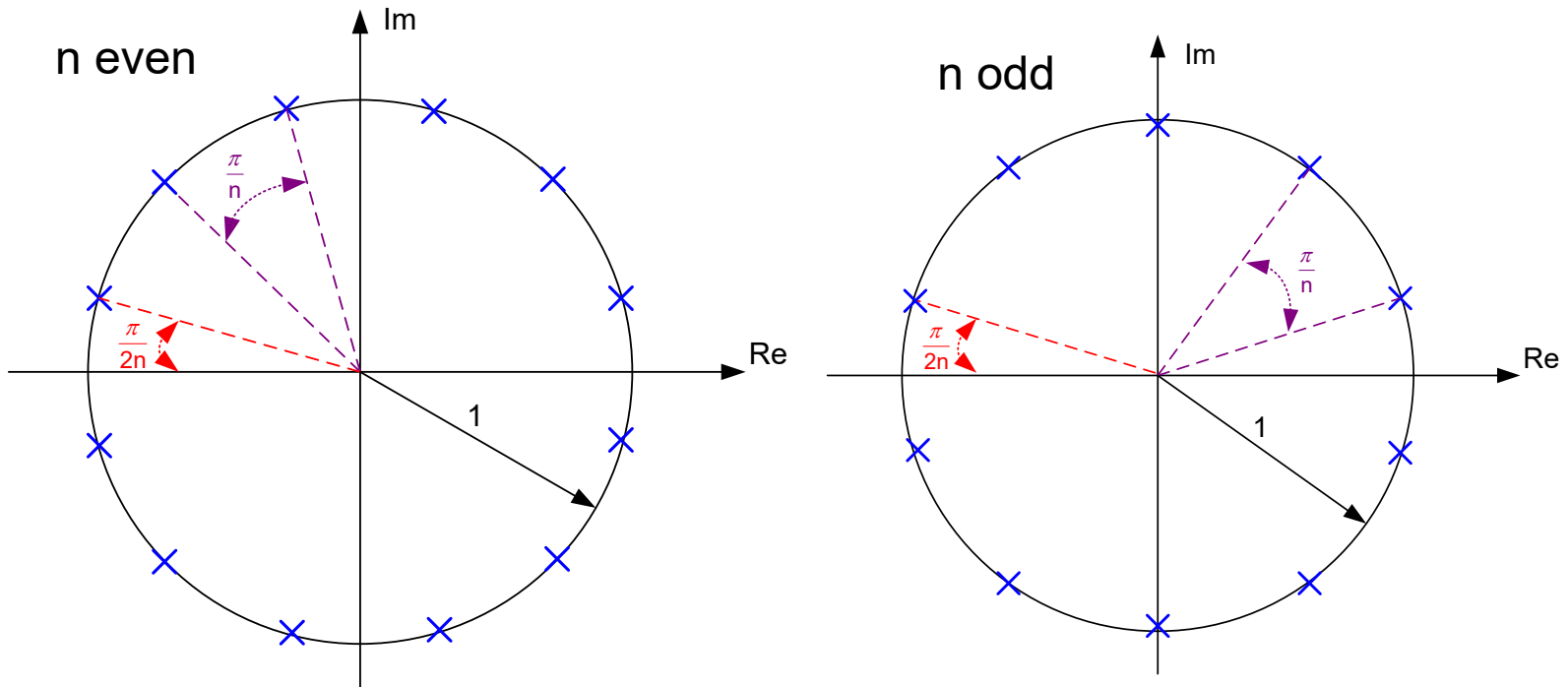

Butterworth Approximation

Roots of -1 are uniformly spaced around a unit circle with symmetry around real axis and symmetry around the imaginary axis

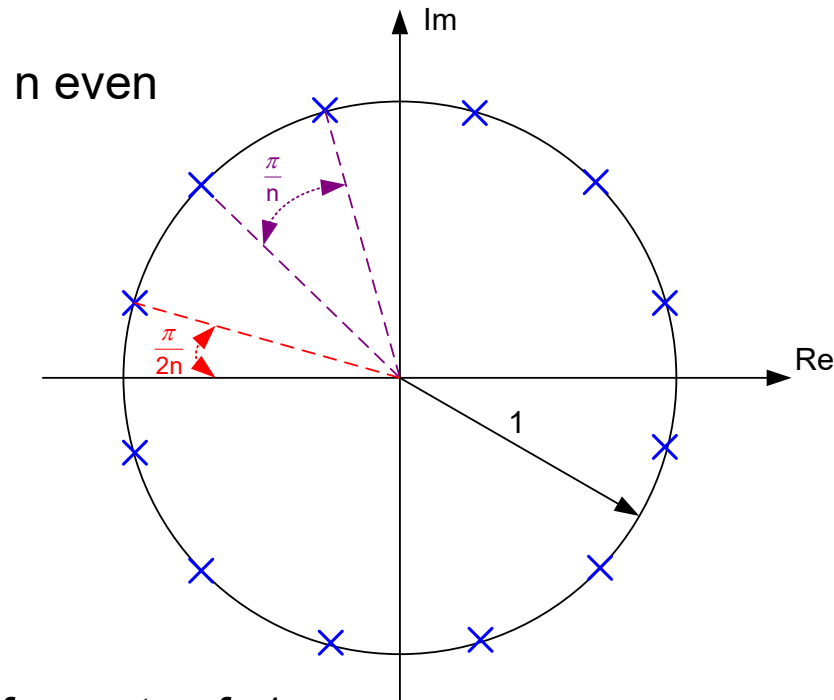

Analytical expression for roots of -1

$$\tilde{\omega}_k = -\cos\left(\left[1 + 2k\right]\frac{\pi}{2n}\right) \pm j \sin\left(\left[1 + 2k\right]\frac{\pi}{2n}\right)$$

$k=0, 1, \dots, n-1$

Does inverse mapping to $T_{AM}(s)$ exist?

Butterworth Approximation

Roots of $T_{BW}(s)$

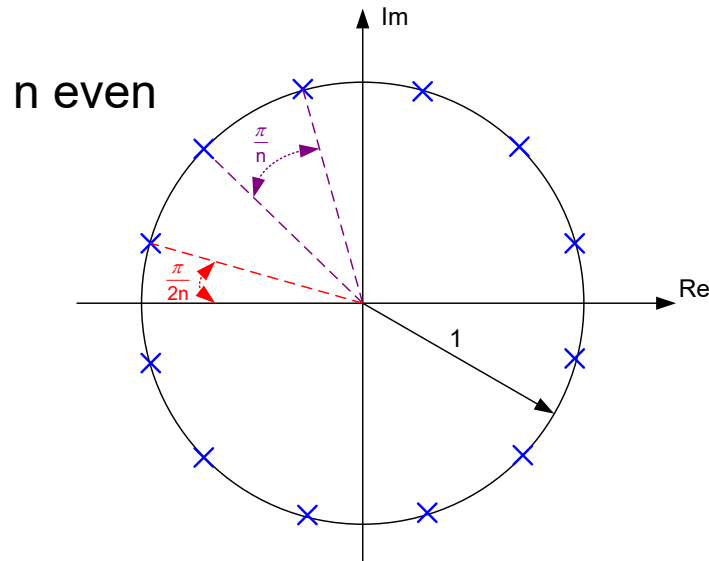

Take roots of $H(\omega)$, rotate by 90° (i.e. multiply by j), keep those in LHP

$$p_k = j\epsilon^{-1/n} \left[-\cos\left([1+2k]\frac{\pi}{2n} \right) \pm j \sin\left([1+2k]\frac{\pi}{2n} \right) \right] \quad (\text{actually denotes 2 poles for each index})$$

for n even

$$p_{k+1} = \epsilon^{-1/n} \left[-\sin\left([1+2k]\frac{\pi}{2n} \right) \pm j \cos\left([1+2k]\frac{\pi}{2n} \right) \right] \quad k=0, 1, \dots, \frac{n}{2}-1 \quad (k=0 \text{ for poles closest to Im axis})$$

for n odd

$$p_n = \epsilon^{-1/n} [-1 + j0] \quad p_k = \epsilon^{-1/n} \left[-\sin\left([1+2k]\frac{\pi}{2n} \right) \pm j \cos\left([1+2k]\frac{\pi}{2n} \right) \right] \quad k=0, \dots, \frac{n-3}{2}$$

Butterworth Approximation

Poles of $T_{BW}(s)$

for n even

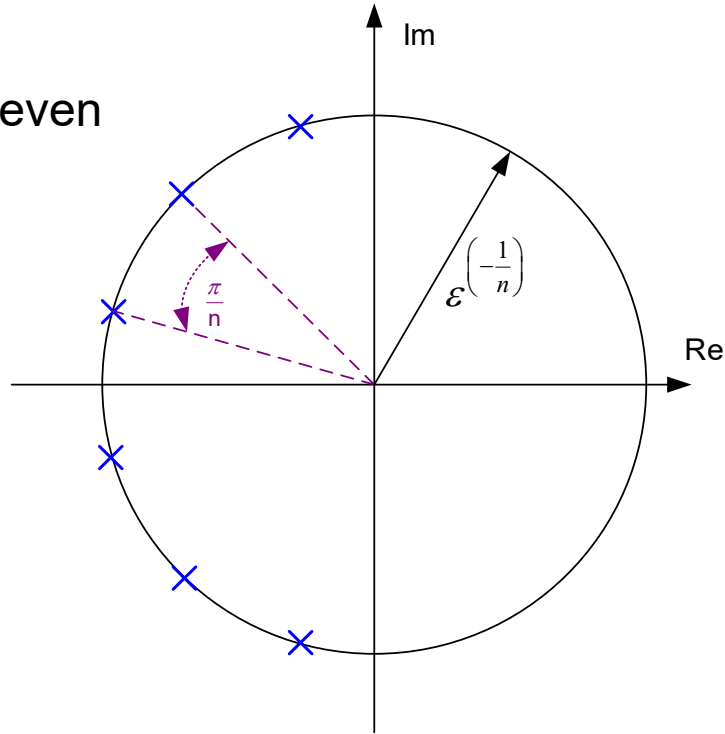

for n odd

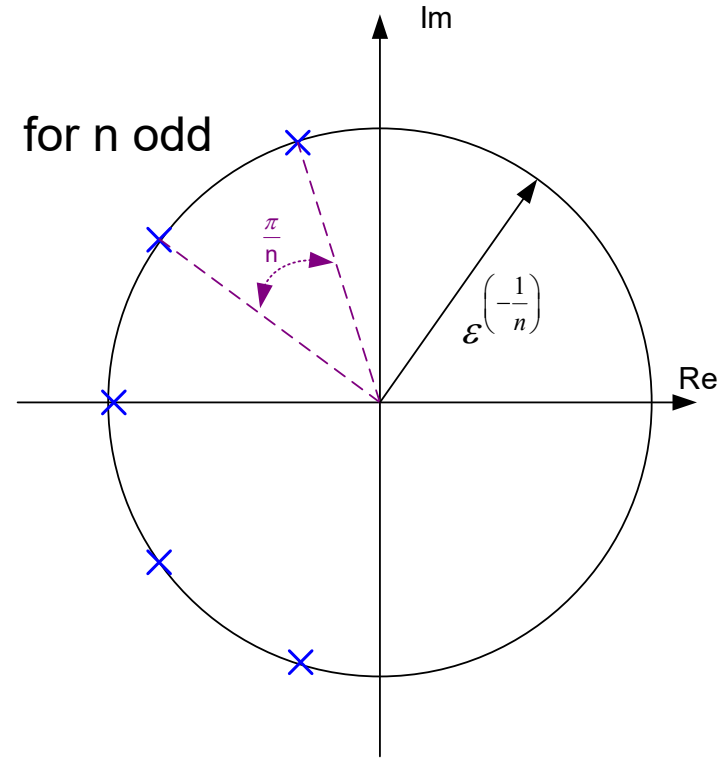

$$p_{k+1} = \epsilon^{-1/n} \left[-\sin\left([1+2k]\frac{\pi}{2n}\right) \pm j \cos\left([1+2k]\frac{\pi}{2n}\right) \right]$$

$$k=0, 1, \dots, \frac{n}{2}-1$$

$$p_n = \epsilon^{-1/n} [-1 + j0]$$

$$p_k = \epsilon^{-1/n} \left[-\sin\left([1+2k]\frac{\pi}{2n}\right) \pm j \cos\left([1+2k]\frac{\pi}{2n}\right) \right] \quad k=0, \dots, \frac{n-3}{2}$$

Butterworth Approximation

What is the Q of the highest Q pole for the BW approximation?

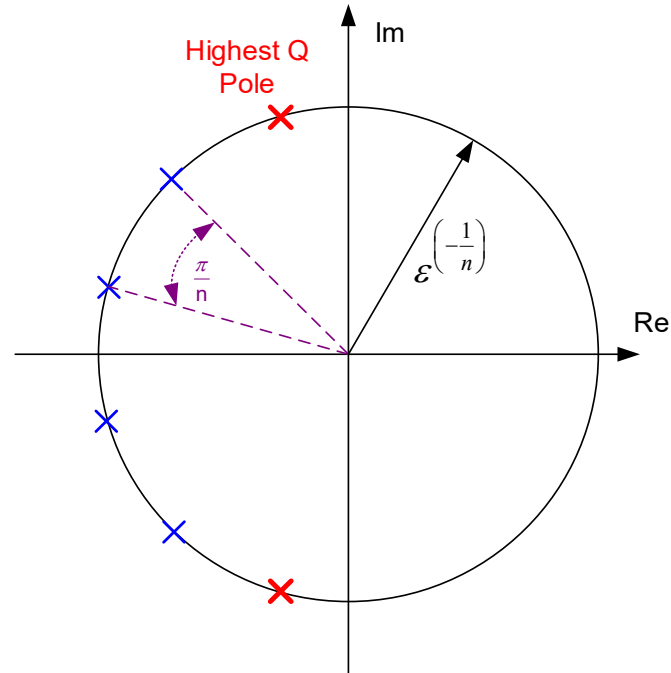

Highest Q pole corresponds to index $k=0$. Consider the Quadrant 2 high-Q pole

$$p_0 = \varepsilon^{-1/n} \left[-\sin\left(\frac{\pi}{2n}\right) + j \cos\left(\frac{\pi}{2n}\right) \right] = \alpha + j\beta$$

But recall

$$s^2 + s\left(\frac{\omega_o}{Q}\right) + \omega_o^2 = s^2 + s(-2\alpha) + (\alpha^2 + \beta^2)$$

thus

$$Q = \frac{\sqrt{\alpha^2 + \beta^2}}{-2\alpha}$$

Butterworth Approximation

What is the Q of the highest Q pole for the BW approximation?

$$p_0 = \varepsilon^{-1/n} \left[-\sin\left(\frac{\pi}{2n}\right) + j \cos\left(\frac{\pi}{2n}\right) \right] = \alpha + j\beta$$

$$Q_{MAX} = \frac{\sqrt{\alpha^2 + \beta^2}}{-2\alpha}$$

$$Q_{MAX} = \frac{\varepsilon^{-1/n} \sqrt{\sin^2\left(\frac{\pi}{2n}\right) + \cos^2\left(\frac{\pi}{2n}\right)}}{2\varepsilon^{-1/n} \sin\left(\frac{\pi}{2n}\right)} = \frac{1}{2 \sin\left(\frac{\pi}{2n}\right)}$$

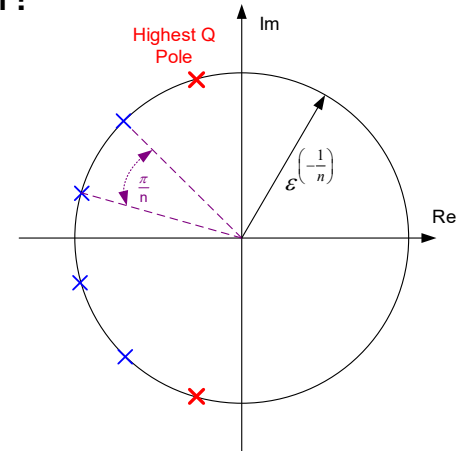

$$Q_{MAX} = \frac{1}{2 \sin\left(\frac{\pi}{2n}\right)}$$

Butterworth Approximation

What order can be used if goal is to keep the highest Q BW pole less than 10?

$$Q_{MAX} = \frac{1}{2 \sin\left(\frac{\pi}{2n}\right)}$$

$$10 = \frac{1}{2 \sin\left(\frac{\pi}{2n}\right)}$$

Solving for n, obtain n=31

What order can be used if goal is to keep the highest Q BW pole less than 2?

$$2 = \frac{1}{2 \sin\left(\frac{\pi}{2n}\right)}$$

Solving for n, obtain n=6

Observe the pole Q of the BW approximation is quite low, even for high order BW approximations!

Butterworth Approximation

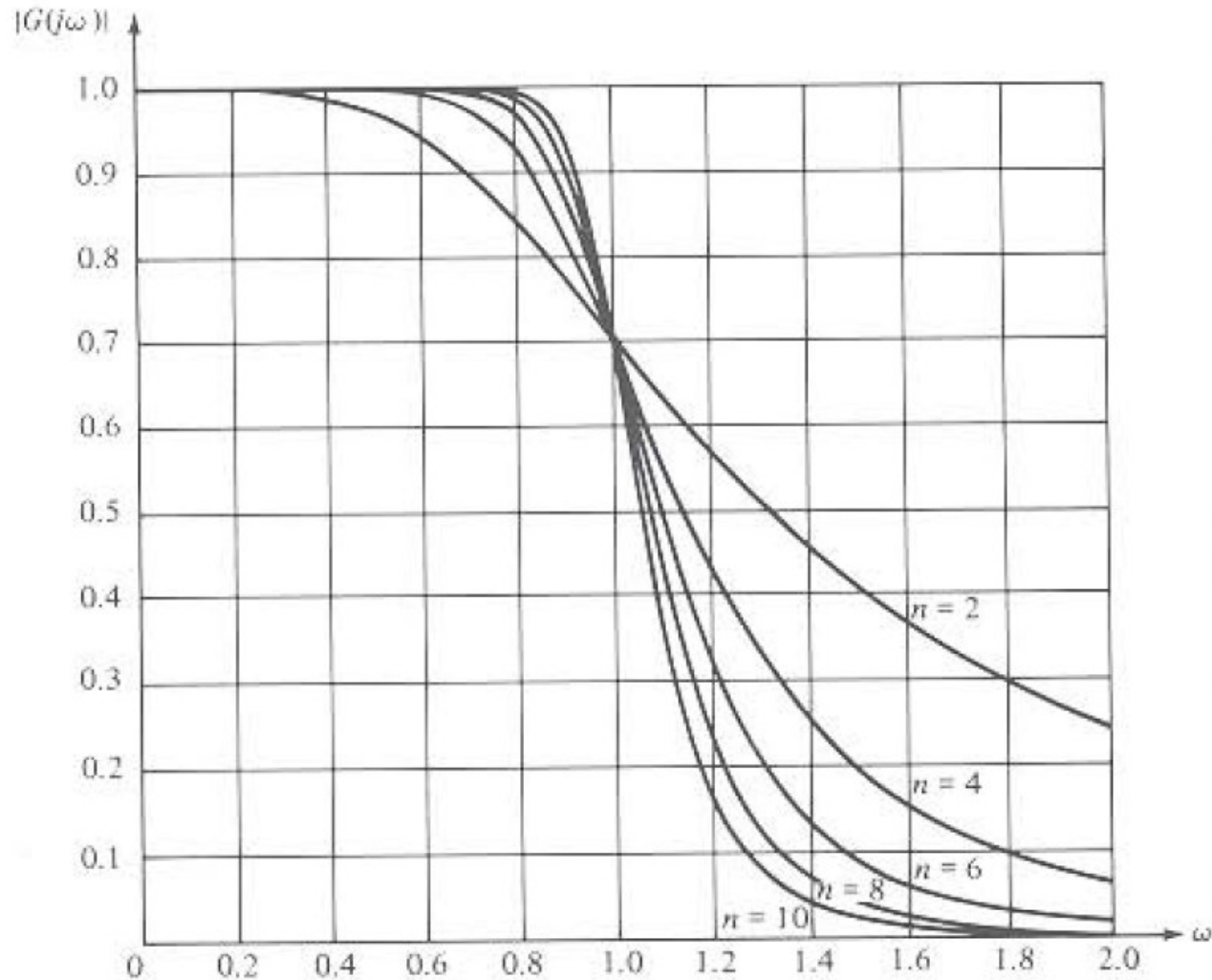

Fig. 17-3a Magnitude of the maximally flat approximation ($\epsilon = 1$)

Figure from Passive and Active
Network Analysis and
Synthesis, Budak

Order needs to be rather high to get steep transition

Butterworth Approximation

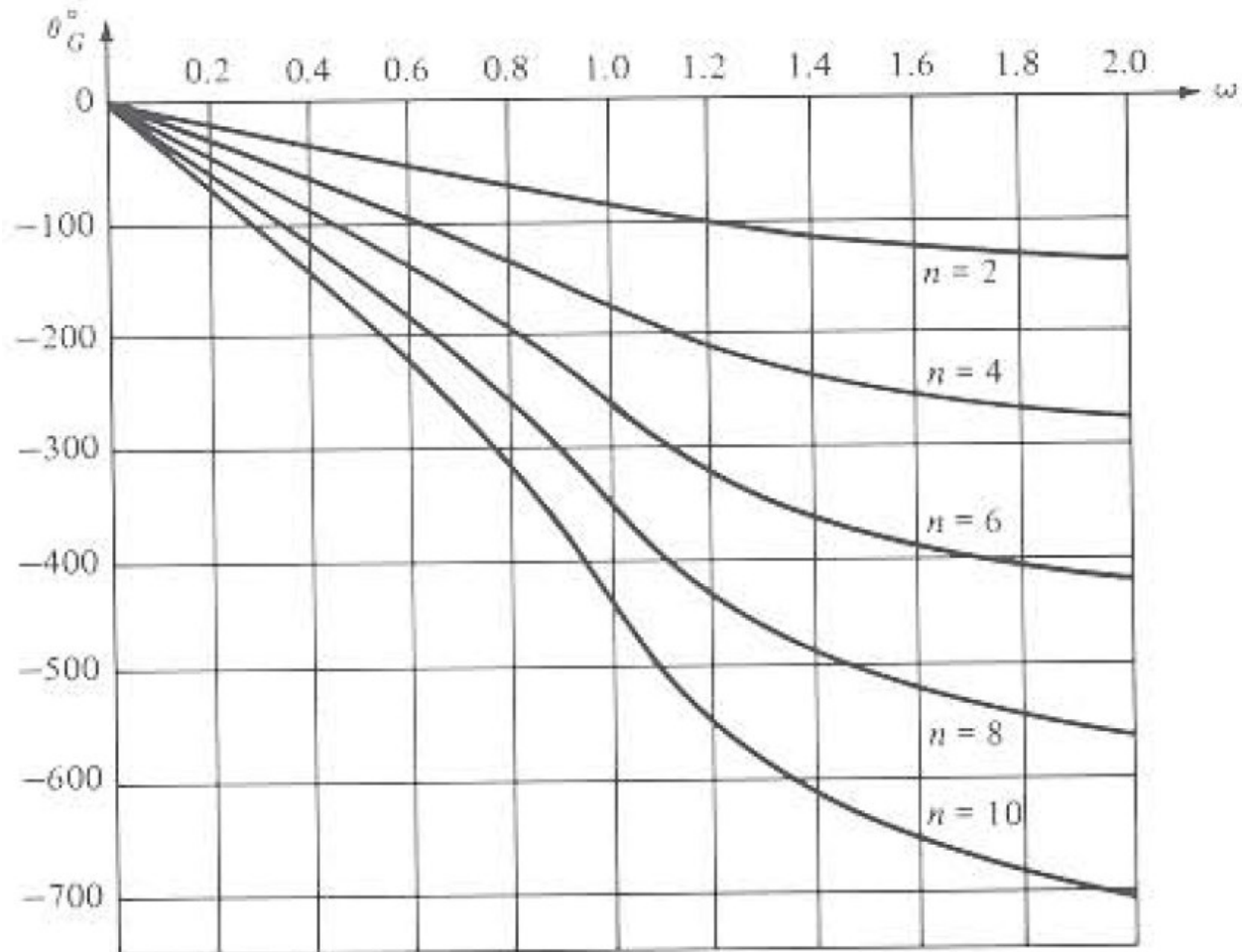

Fig. 17-3b Phase of the maximally flat approximation ($\epsilon = 1$)

Figure from Passive and Active Network Analysis and Synthesis, Budak

Phase is quite linear in passband (benefit unrelated to design requirements)

Butterworth Approximation

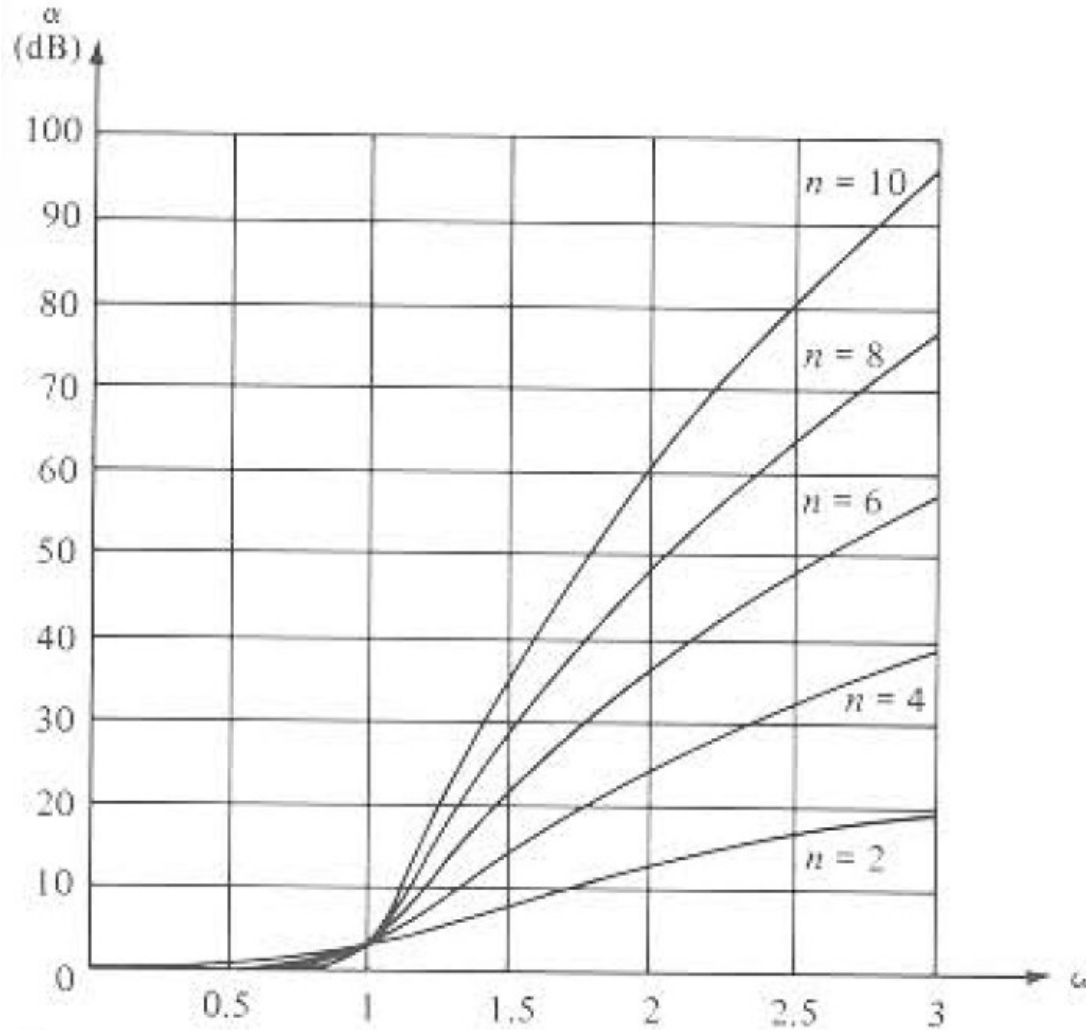

Figure from Passive and Active Network Analysis and Synthesis, Budak

Fig. 17-3c dB attenuation produced by the maximally flat approximation ($\epsilon = 1$)

Attenuation in stopband is quite gradual

Butterworth Approximation

Table 17-1 Maximally flat (at $\omega = 0$) approximation $G_n(s) = \frac{1}{D_n(s)}$ (3.01-dB ripple)

$$D_1 = s + 1$$

$$D_2 = s^2 + 1.4142s + 1 = (s + 0.7071)^2 + 0.7071^2$$

$$D_3 = s^3 + 2.0000s^2 + 2.0000s + 1 = (s + 1.0000)[(s + 0.5000)^2 + 0.8660^2]$$

$$D_4 = s^4 + 2.6131s^3 + 3.4142s^2 + 2.6131s + 1$$

$$= [(s + 0.3827)^2 + 0.9239^2][(s + 0.9239)^2 + 0.3827^2]$$

$$D_5 = s^5 + 3.2361s^4 + 5.2361s^3 + 5.2361s^2 + 3.2361s + 1$$

$$= (s + 1.0000)[(s + 0.3090)^2 + 0.9511^2][(s + 0.8090)^2 + 0.5878^2]$$

$$D_6 = s^6 + 3.8637s^5 + 7.4641s^4 + 9.1416s^3 + 7.4641s^2 + 3.8637s + 1$$

$$= [(s + 0.2588)^2 + 0.9659^2][(s + 0.7071)^2 + 0.7071^2][(s + 0.9659)^2 + 0.2588^2]$$

$$D_7 = s^7 + 4.4940s^6 + 10.0978s^5 + 14.5918s^4 + 14.5918s^3 + 10.0978s^2 + 4.4940s + 1$$

$$= (s + 1.0000)[(s + 0.2225)^2 + 0.9749^2][(s + 0.6235)^2 + 0.7818^2]$$

$$\times [(s + 0.9010)^2 + 0.4339^2]$$

$$D_8 = s^8 + 5.1258s^7 + 13.1371s^6 + 21.8462s^5 + 25.6884s^4 + 21.8462s^3 + 13.1371s^2$$

$$+ 5.1258s + 1$$

$$= [(s + 0.1951)^2 + 0.9808^2][(s + 0.5556)^2 + 0.8315^2][(s + 0.8315)^2 + 0.5556^2]$$

$$\times [(s + 0.9808)^2 + 0.1951^2]$$

$$D_9 = s^9 + 5.7588s^8 + 16.5817s^7 + 31.1634s^6 + 41.9864s^5 + 41.9864s^4 + 31.1634s^3$$

$$+ 16.5817s^2 + 5.7588s + 1$$

$$= (s + 1.0000)[(s + 0.1737)^2 + 0.9848^2][(s + 0.5000)^2 + 0.8660^2]$$

$$\times [(s + 0.7660)^2 + 0.6428^2][(s + 0.9397)^2 + 0.3420^2]$$

$$D_{10} = s^{10} + 6.3925s^9 + 20.4317s^8 + 42.8021s^7 + 64.8824s^6 + 74.2334s^5 + 64.8824s^4$$

$$+ 42.8021s^3 + 20.4317s^2 + 6.3925s + 1$$

$$= [(s + 0.1564)^2 + 0.9877^2][(s + 0.4540)^2 + 0.8910^2][(s + 0.7071)^2 + 0.7071^2]$$

$$\times [(s + 0.8910)^2 + 0.4540^2][(s + 0.9877)^2 + 0.1564^2]$$

Figure from Passive and Active Network Analysis and Synthesis, Budak

Pole locations and denominator polynomial

Butterworth Approximation

$$D_6 = s^6 + 3.8637s^5 + 7.4641s^4 + 9.1416s^3 + 7.4641s^2 + 3.8637s + 1$$

Question: Why are the coefficients of s^5 , s^4 , s^3 , s^2 and s not equal to 0?

Answer: Coefficients vanished in $H_{BW}(\omega^2)$ but not in $T_{BS}(s)$

Butterworth's vision was a bit different than what we presented but the results are completely attributable to Butterworth

From the seminal Butterworth paper:

at first that we have perfect freedom in regard to the electrical constants of the elements and then these have been chosen with a view to obtaining the nearest approximation to the condition of uniform sensitivity in the "pass" region, and zero sensitivity in the "stop" region.

In the case of the low pass filter, if f_0 is the "cut off" frequency and f (xf_0) is any other frequency, the aim is to obtain a filter factor F , that is, the ratio of the output e.m.f. to the input e.m.f., of the form

$$F = (1 + x^m)^{-1} \dots \dots \dots (1),$$

where m increases with the number of elements employed. It is clear that as m increases,

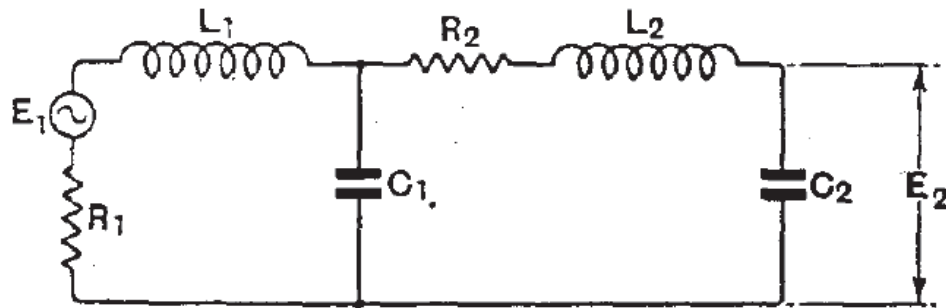

Fig. 2.

F will approximate more and more closely to the value unity when x is less than unity, and to zero when x is greater than unity.

Butterworth used a trig identity to factor (1) into a product of 4th order terms and then synthesized a circuit that realized each factor (no mention made of inverse mapping to $T(s)$)

Butterworth Approximation

$$H(\omega) = \frac{1}{1 + \varepsilon^2 \omega^{2n}} \longleftrightarrow T_{BW}(s)$$

Summary

- Widely Used Analytical Approximation
- Characterized by $\{\varepsilon, n\}$
- Maximally flat at $\omega=0$
- Almost all emphasis placed on characteristics at single frequency ($\omega=0$)
- Transition not very steep (requires large order for steep transition)
- Pole Q is quite low
- Pass-band phase is quite linear (no emphasis was placed on phase!)
- Poles lie on a circle
- Simple closed-form analytical expressions for poles and $|T(j\omega)|$

Did Butterworth get lucky since the inverse mapping from $H(\omega)$ to $T(s)$ exists for all n and ε ?

Remember we are working on the approximation problem with no considerations at this point for synthesis!

Filter Design Process

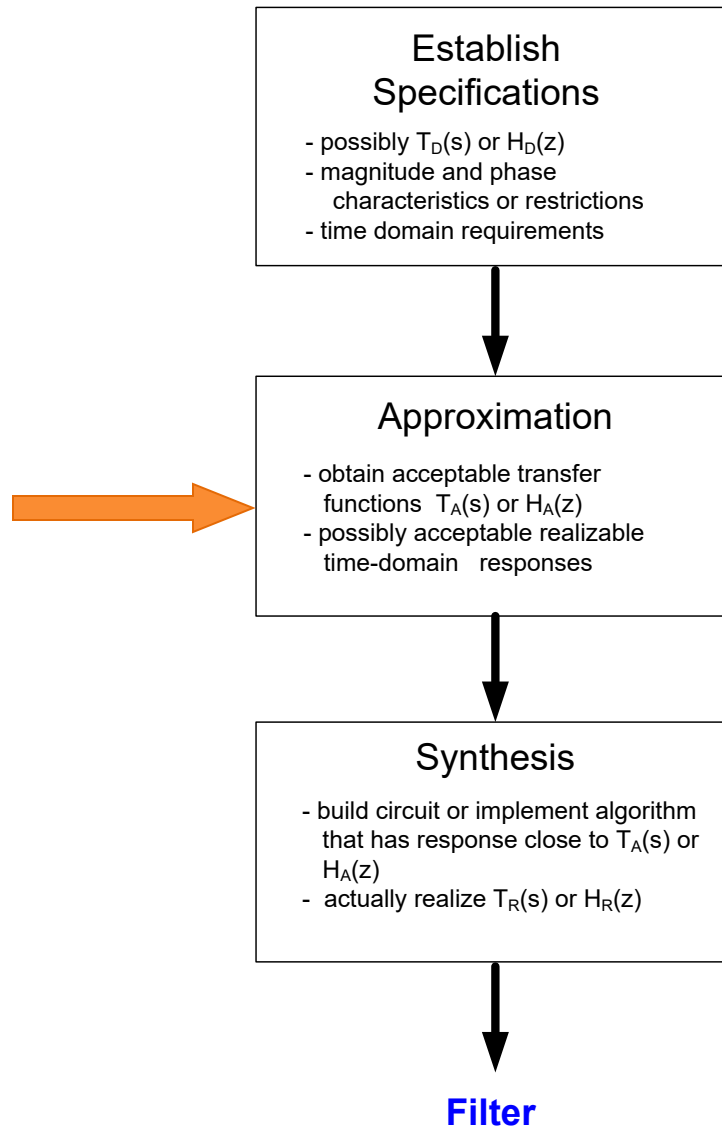

Butterworth Approximation

What can be done to sharpen the transition of the BW approximation?

Add zeros on imaginary axis in stop band

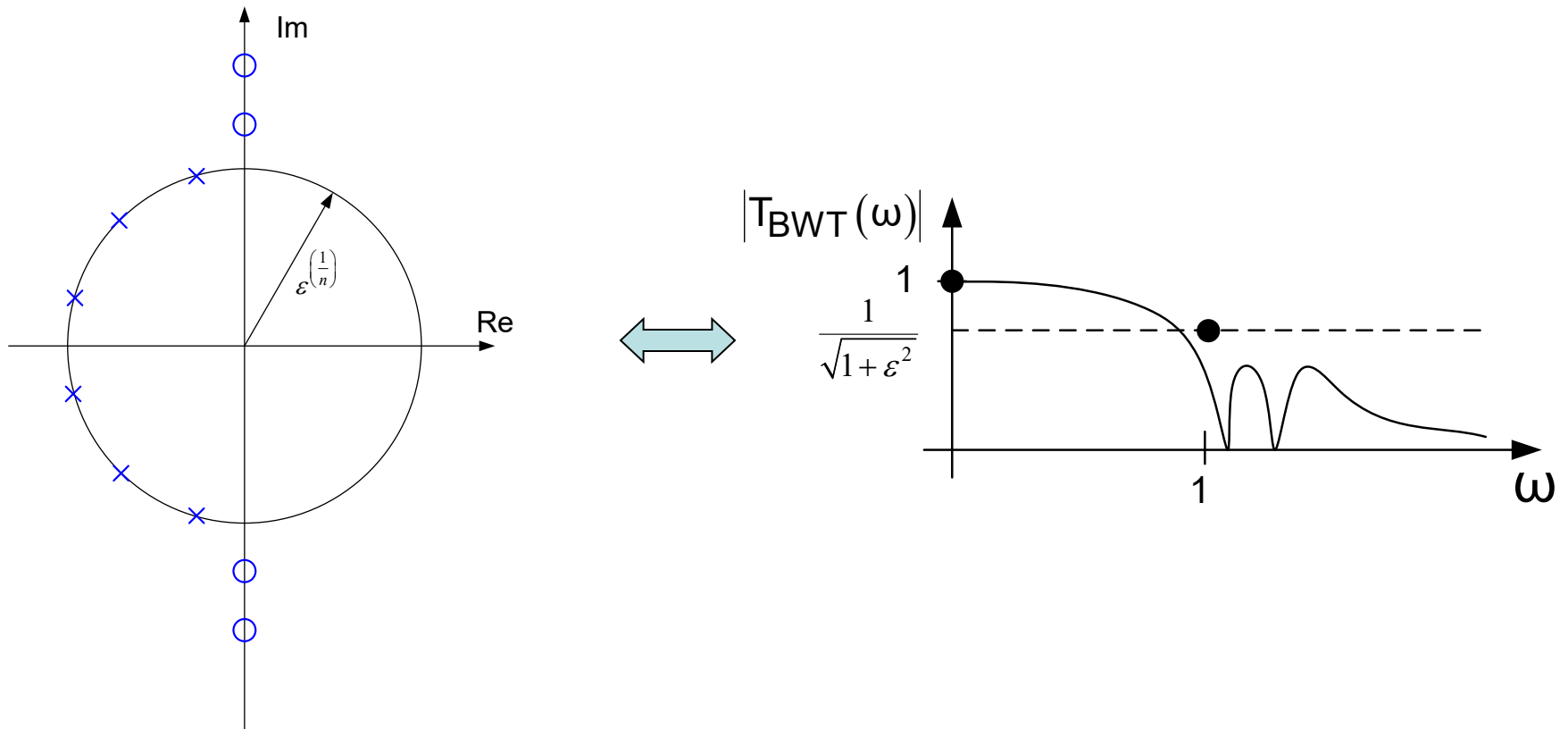

- May need to readjust the poles to get good transition region
- Analytical expressions for poles may not be easy to obtain



Stay Safe and Stay Healthy !

End of Lecture 9